

SmartSolarBox

The Power-Package

The revolution in
flat roof PV-Systems

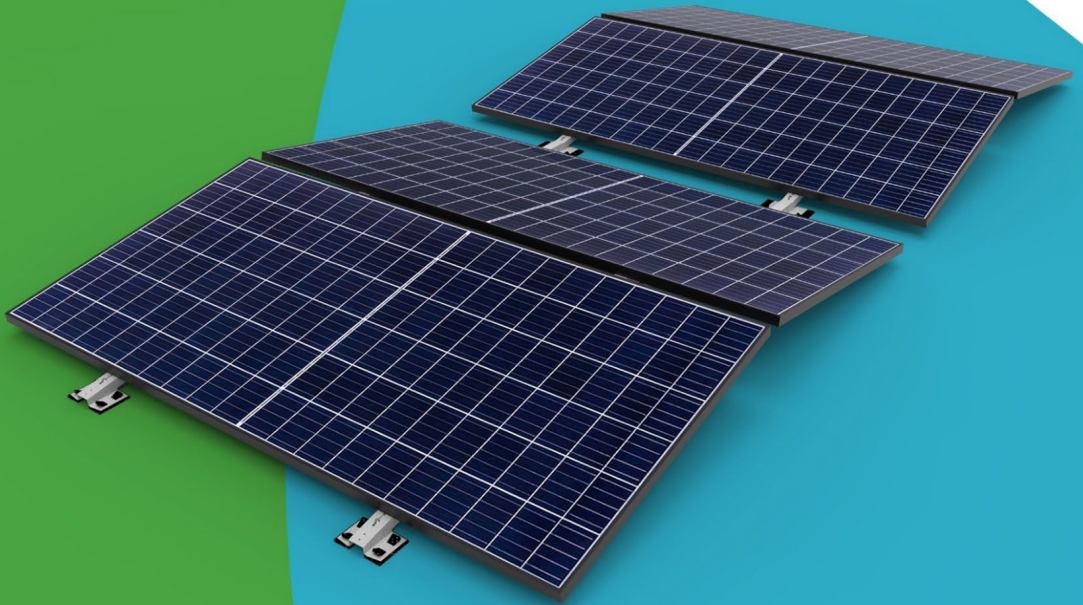

Operation Manual
Crane Lifting Unit LAM-SSB5

Table of contents:

1	Definition load handling equipment	3
2	assessment bases	3
3	Machine description (technical product data)	3
4	General information and notes	4
5	Smartvolt crane beam for crane operation	5
5.1	General information	5
5.2	Connecting the SmartSolarBox.....	5
5.3	Crane beam 103719 LAM-SSB5-F for the installation of solar systems.....	6
5.4	Crane beam 103721 LAM-SSB5-P for use in production	7
6	Notes on CE marking and risk assessment	7
7	Transport	8
8	Inspection / Maintenance / Repair.....	8
8.1	Inspection	8
8.1.1	Testing at the manufacturing plant	8
8.1.2	Check before first use.....	8
8.1.3	Check before each use	8
8.1.4	Regular examination	9
8.1.5	Extraordinary examination	9
8.1.6	Deformation and wear limits of load-bearing elements	9
8.2	Maintenance	9
8.3	Repair	9
9	Hints	10
10	Drawings.....	11
11	EC Declaration of Conformity	12

1 Definition load handling equipment

A component or piece of equipment that does not belong to the hoist which enables the gripping of the load, and which is placed between the machine and the load or on the load itself, or which is intended to become an integral part of the load, and which is placed on the market separately. All slings and their components are also considered load handling equipment.

2 assessment bases

- Machinery Directive 2006/42 EC
- DIN EN 13155 Crane - Safety - Non-fixed load lifting attachments
- DIN EN ISO 12100 Safety of machinery
General principles for design — Risk assessment and risk reduction (ISO12100:2010)
- DIN 15003 Lifting Appliances; Load Suspending Devices, Loads and Forces; Definitions
- DGUV rule 109-017 Operation of load handling attachments and slings in hoisting operations

3 Machine description (technical product data)

Manufacturer:	Smartvolt AG	
Load handling equipment:	Crane traverse with fixed working width	
Series	Crane traverse for SmartSolarBox Version 5.x	
Type designation:	LAM-SSB5-F	LAM-SSB5-P
Payload:	175kg	
Working width:	1147mm	
Load center:	middle	
Own weight:	4.2kg	9.0kg
Serial no.:	see delivery note/ type plate	
Construction year:	see delivery note/ type plate	

EU – Declaration of Conformity in terms of the EC Machinery Directive 2006/42/EC

The copyright of these technical documents remains with Smartvolt AG.

We reserve the right to make changes. All information was created to the best of our knowledge and belief. However, no liability can be derived from this.

© Smartvolt AG – Status 10/2022

Use, reprinting and duplication of this document is only permitted with the express permission of Smartvolt AG. Any misuse is punishable and can oblige you to pay damages.

4 General information and notes

Operating instructions are a necessary part of the scope of delivery of every load handling equipment (short LHE). The manufacturer is obliged to issue these together with the CE declaration. The operating instructions must be read carefully and kept. The entrepreneur must ensure that the operating instructions can be viewed at any time in an easily accessible place at the place of use. Lost operating instructions can be obtained from the manufacturer. Only persons appointed by the entrepreneur who are familiar with these tasks may be commissioned with the independent application of the LHE. The existence of an operating manual does not release the user from his individual obligation to check. The operating instructions cannot replace the necessary, individual training of the user. According to DIN EN 13155, "Loose load handling equipment", a maximum of 20,000 load changes are permitted. After that, the maximum life expectancy of the load handling device has been reached. The LHE must be decommissioned, scrapped, or if possible, completely overhauled. The trade association rule DGVU 109-017 and the other rules of technology (e.g. EN standards, other trade association rules or regulations) must always be observed and complied with. If the DGVU 109-017 is not available, it can be downloaded from <https://publikationen.dguv.de>.

The supplied LHE was specially designed for lifting and setting down the SmartSolarBox.

- The LHE may only be used for vertical lifting with an even (symmetrical) load distribution. The SmartSolarBox has a load-symmetrical design.
- Any diagonal pull with the LHE is not permitted.
- LHE must be stored in a stable manner.
- On the one hand, the crane hook must be above the center of gravity of the load and, on the other hand, it must be in the vertical alignment of the center of gravity of the load.
- When moving the LHE, swinging or hitting objects and parts of the building must be prevented.
- Pulling against resistance, such e.g. goods that are close together and touching each other should be avoided, as the friction of the goods standing next to each other can result in higher load values than the permissible load-bearing capacity.
- **It is forbidden for people to remain under the suspended load or in the danger area!**
- All fittings and accessories must be selected correctly according to the load capacity and type of attachment. Lifting gear with mechanical damage, deformation or exceeded permissible cross-section reductions must not be used. This applies to all eye-lets, bolts, brackets, shackles, hooks, chains, etc. The permissible cross-section reductions can be seen in the professional association regulation DGVU 109-017 or, if necessary, in the additional manufacturer information.
- All fittings must be able to move freely.
- Any socket pins must be secured.
- The maximum operating temperatures for all LHE are -10 °C to +80 °C. When used in other temperature ranges, the manufacturer's separate approval is required. The specified carrying capacity must not be exceeded.
- Insofar as the information does not directly relate to the delivered LHE, these are to be understood as recommendations. Proper handling of load handling equipment protects you from personal injury and damage to property.
- The LHE is only to be used for the purposes described in the operating instructions (intended use). Improper use can lead to significant personal injury and damage to property.

5 Smartvolt crane beam for crane operation

5.1 General information

The Smartvolt LHE may only be operated by trained personnel. The crane operator or a qualified person according to DGUV 109-017 must install the crane beam on the crane. The crane hook to which the LHE is attached must have a functioning safety mechanism and must close securely after it is attached.

When lifting a load, the crane hook must always be above the center of gravity of the load. If the crane hook is not above the center of gravity of the load, the entire system will tilt when lifting until the center of gravity is below the crane hook. Especially when lifting the SmartSolarBox out of the transport box, this can lead to the solar modules tilting or jamming on the walls of the transport box and thus to an impermissible increase in the load forces.

The maximum permissible travel speed when using the Smartvolt crane beam is 0.5 m/s.

Intended Use:

Smartvolt crane beams are only approved for lifting the SmartSolarBox .

5.2 Connecting the SmartSolarBox

The load may only be attached by a qualified person in accordance with DGUV 109-017.

The crane beam is attached to the two axes of the Smartsolarbox.

For this purpose, the crane beam already installed on the crane is placed centrally above the smart solar box. (1) By moving the actuator rod of the jib, the two lifting rods of the jib can be opened. (2) Now the bar can be placed on the two axes of the Smartsolarbox. (3) The integrated return spring ensures that the crane beam's holding mechanism is closed. The closure is successful when the actuator rod is back in its original position.

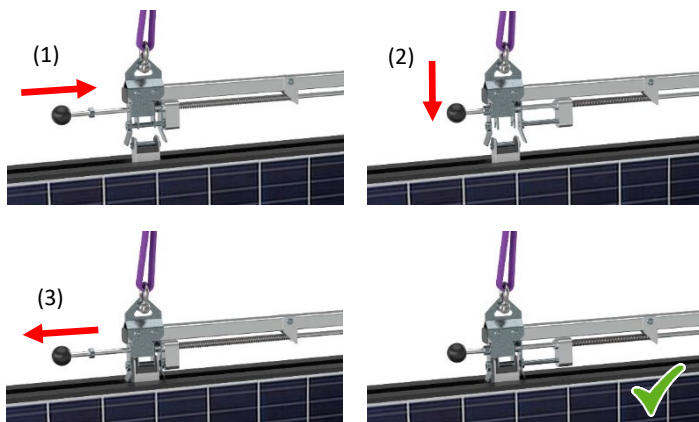

The SmartSolarBox is picked up and transported without the effect of pressure forces. The integrated return spring ensures that the load-handling-device always remains closed when not in use. The opening bar must never be operated as long as the load is not set down. There is a risk of accidents!

5.3 Crane beam 103719 *LAM-SSB5-F* for the installation of solar systems



This crane beam was developed to transport the SmartSolarBox. For the installation of a solar system with a crane, 2 pcs. of this LHE are used. For each LHE 2 pcs. lifting straps or round slings with a useful length $\geq 4.5\text{m}$ and suitable curved shackles with safety device are required. Smartvolt recommends components with a payload of 1t.

The lifting straps are each connected to the eyelets provided on the crane beam using shackles and hooked together in a crane hook with safety device.

Before lifting the load, make sure that the crane hook is centered over the load. An oblique pull must be avoided so that the load does not tilt in the transport box.

Operation of the crane beam is only permitted up to a maximum wind speed of 30 km/h. At higher wind speeds, impermissible loads occur in the crane beam and there is a considerable risk of accidents!

While working with the crane beam and the SmartSolarBox, safety shoes must be worn to prevent feet from being crushed when setting down the SmartSolarBox. The use of work gloves is recommended to prevent possible injuries to the hands.

In addition, those employees who receive and set up the SmartSolarBox on the roof must protect themselves individually against falling - unless there is collective protection against falling.

5.4 Crane beam 103721 *LAM-SSB5-P* for use in production



This crane beam was developed for use in SmartSolarBox production. The central crane shackle enables operation on a bridge crane with a low lifting height. The crane beam can be operated directly on a crane hook with a safety device.

For lifting a SSB4 or 2 pcs. SSB2 requires 2 crane beams, which are attached to the same crane hook. A single SSB2 can be transported with a single crane beam.

Before lifting the load, make sure that the crane hook is centered over the load. An oblique pull must be avoided at all costs so that the load does not tilt on the assembly table.

While working with the crane beam and the SmartSolarBox to prevent crushing the use of work gloves is recommended to prevent possible injuries to the hands.

Caution: The LAM-SSB5-P crane beam is significantly heavier than the LAM-SSB5-F crane beam and is therefore not approved for use in the field.

6 Notes on CE marking and risk assessment

The CE declaration and operating instructions are only valid if the associated LHE can be clearly identified and assigned. This assignment is given by the manufacturer's nameplate. A change or falsification of the manufacturer's information can lead to the expiry of the EC declaration of conformity. If anything is unclear, the manufacturer must be asked or contacted. The use of a LHE is usually not limited to a firmly defined and always the same way of working. The LHE is only to be used for the purposes described in the operating instructions (intended use). Improper use can lead to significant personal injury and damage to property. The manufacturer expressly emphasizes that he accepts no liability whatsoever for the proper installation of the LHE in the overall system. The supplied LHE was developed for the SmartSolarBox Version 5.0. Changes made to the LHE can result in the LHE no longer meeting the requirements of various directives or standards. Here it is necessary to check and comply with them.

7 Transport

For transport, the load-carrying equipment must be fixed in such a way that it cannot fall or collide with other objects.

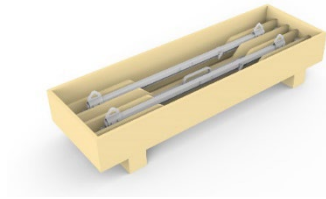

A suitable transport box is sold by Smartvolt for transport to and from the construction site.

8 Inspection / Maintenance / Repair

8.1 Inspection

8.1.1 Testing at the manufacturing plant

The lifting device was subjected to an internal production control in the manufacturing plant.

8.1.2 Check before first use

Before it is put into operation for the first time, the load handling device must be checked by an expert in accordance with DGUV 109-017. Any defects (e.g. transport damage) must be rectified. The tests before the first start-up are essentially visual and functional tests. They must include checking the condition of the components and equipment, the intended assembly and the completeness and effectiveness of the safety equipment. Furthermore, the presence of the type-plate with the following data must be checked:

- Manufacturer's identification data
- Payload
- Serial number
- CE mark

A competent person is someone who, based on their professional training and experience, has sufficient knowledge in the field of load handling devices and is sufficiently familiar with the relevant state occupational health and safety regulations, accident prevention regulations, guidelines and generally recognized rules of technology (e.g. DIN EN standards) to be able to work safely. Assess the condition of load handling equipment.

8.1.3 Check before each use

The load handling device should be subjected to a visual inspection by the user/operator before each use. These tests are essentially visual and functional tests. They must include checking the condition of the components and equipment (deformations), the proper assembly and the completeness and effectiveness of the safety equipment. In doing so, attention must also be paid to contamination that could influence or limit the operation of the load handling device.

8.1.4 Regular examination

The entrepreneur must ensure that load handling devices are inspected by an expert at intervals of no more than one year. Depending on the operating conditions of the load handling devices, tests may be required at shorter intervals than one year. This applies, for example, in the case of particularly frequent use, increased wear, corrosion or the effects of heat or if increased susceptibility to faults is to be expected. The regular tests are essentially visual and functional tests. They include checking the condition of the components and equipment (checking for cracks, deformation, heavy corrosion and wear), correct assembly and the completeness and effectiveness of the safety equipment. In doing so, attention must also be paid to contamination that could influence or limit the operation of the load handling device. All moving parts such as hooks, bolts, shackles, chain links, screw connections, cotter pins, springs, axles, rollers, cable deflections, gas pressure dampers, etc. must be checked for completeness, functional reliability, wear and mobility. In the case of wear and tear on moving parts, the max. reduction in cross-section specified in the professional association regulation DGUV 109-017 must be taken into account. Friction linings may be worn down to the wear limit. The prerequisite is that the linings have been worn down evenly (for values, see wear limits). Furthermore, the presence of the type-plate and the identification of the load handling device must be checked.

8.1.5 Extraordinary examination

Extraordinary tests according to DGUV 109-017 must be carried out on load handling equipment after damage and special events that can affect the load-bearing capacity. Accessories must be checked in accordance with the respective provisions of the trade association regulation DGUV 109-017. They must include checking the condition of the components and equipment (checking for cracks, deformation, etc.) based on the intended assembly and the completeness and effectiveness of the safety equipment. All moving parts, such as hooks, bolts, shackles, chain links, screw connections, cotter pins, springs, axles, rollers, rope deflections, gas pressure absorbers, etc. must be checked for completeness, functional reliability, wear and mobility. In the case of wear and tear on moving parts, the max. reduction in cross-section specified in the professional association regulation DGUV 109-017 must be taken into account. Friction linings may be worn down to the wear limit. The prerequisite is that the linings have been worn down evenly (for values, see wear limits)

8.1.6 Deformation and wear limits of load-bearing elements

Abrasion and damage may only be permitted within the area in which the occupational safety of the component is not impaired. Components with a reduction in cross-section of 5.0% or more must be replaced.

8.2 Maintenance

Smartvolt load handling devices are largely maintenance-free.

8.3 Repair

No repairs may be carried out on the LHE without consultation with the manufacturer. If a repair is carried out by the operator after consultation with the manufacturer, a test certificate must be created. No changes may be made to the LHE. Changes made to the LHE can mean that it no longer meets the requirements of various guidelines or standards.

9 Hints

Failure to comply with the above instructions may result in the loss of product liability or warranty claims.

10 Drawings

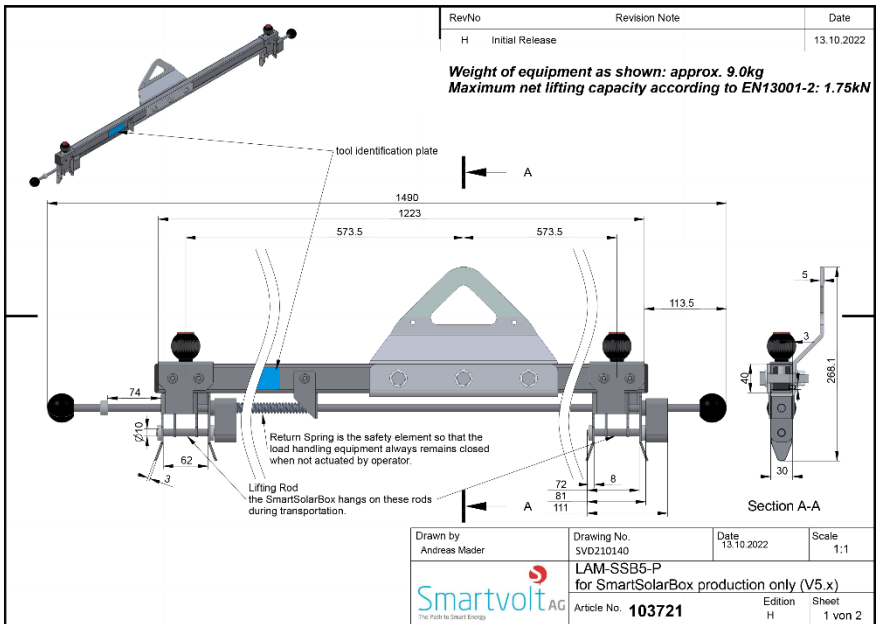
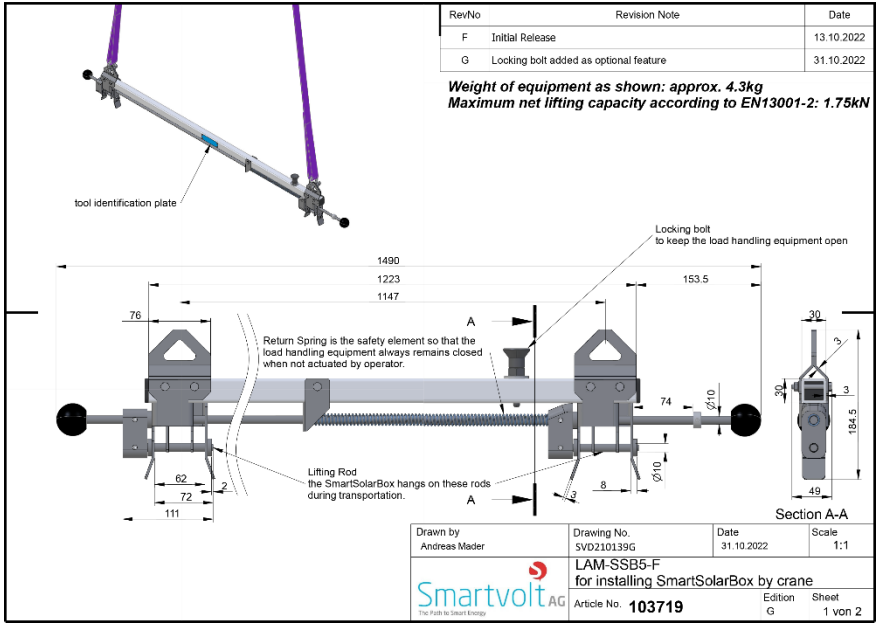

11 EC Declaration of Conformity

EG-Konformitätserklärung

Der Hersteller,

Smartvolt AG
Byfangstrasse 3
3360 Herzogenbuchsee
SCHWEIZ



erklärt in alleiniger Verantwortung, dass die Maschine,

Bezeichnung: Kranbalken
Model: LAM-SSB5-F und LAM-SSB5-P

allen einschlägigen Bestimmungen der Richtlinie 2006/42/EG - Maschinenrichtlinie entspricht.

Folgende harmonisierte Normen wurden angewandt:

Norm	Titel
EN ISO 12100:2010	Sicherheit von Maschinen — Allgemeine Gestaltungsleitsätze — Risikobeurteilung und Risikominderung (ISO 12100:2010)
DIN EN 13155:2009-08	Krane - Sicherheit - Lose Lastaufnahmemittel

Folgende sonstige technische Normen und Spezifikationen wurden angewandt:

- Keine

Dokumentationsbevollmächtigter:
Name: Andreas Mader
Anschrift: siehe Adresse des Herstellers

Unterschrift, Angaben zum Unterzeichner:

Herzogenbuchsee, 01.09.2022

(Andreas Mader, Geschäftsführer)

The Path to Smart Energy
Byfangstrasse 3, CH-3360 Herzogenbuchsee
Telefon: +41 62 961 92 10 Mail: info@smartvolt.ch

